



Kiwa Ltd.
 Unit 5 Prime Park Way
 Prime Enterprise Park
 Derby
 DE1 3QB
 T: +44 (0)1332 383333
 E: uk.bpenquiries@kiwa.com
 W: www.kiwa.co.uk/bda

BAW-19-097-S-A-UK
BDA Agrément®
Safewall® with Swisspearl A2
Rainscreen Cladding System

Roofing & Cladding Materials Ltd.
 Lonsdale Chambers
 Lonsdale Street
 Stoke-on-Trent
 ST4 4BT
 T: +44 (0)845 519 8641
 E: contact@benx.co.uk
 W: www.benx.co.uk

SCOPE OF AGRÉMENT

This Agrément relates to Safewall® with Swisspearl A2 Rainscreen Cladding System (hereinafter the 'System'), a mechanically fixed, non-loadbearing, drained and vented rainscreen cladding system, suitable for installation on light gauge steel framed (hereinafter 'LGSF') supporting walls. For use on new residential and non-residential high-rise buildings up to and over 18 m in height in the UK.

SYSTEM DESCRIPTION

The System comprises an aluminium subframe, sheathing boards, breather membranes, tape, isolators, insulation boards and cladding panels including cladding panel fasteners. The subframe comprises brackets, vertical rails (L/T-profiles) and subframe fasteners. The cladding panels are available in a range of colours with a maximum size of 1,250 mm by 3,050 mm and standard thicknesses of 8 or 12 mm. Different combinations of System components can be used, subject to the project-specific design.

SYSTEM ILLUSTRATION

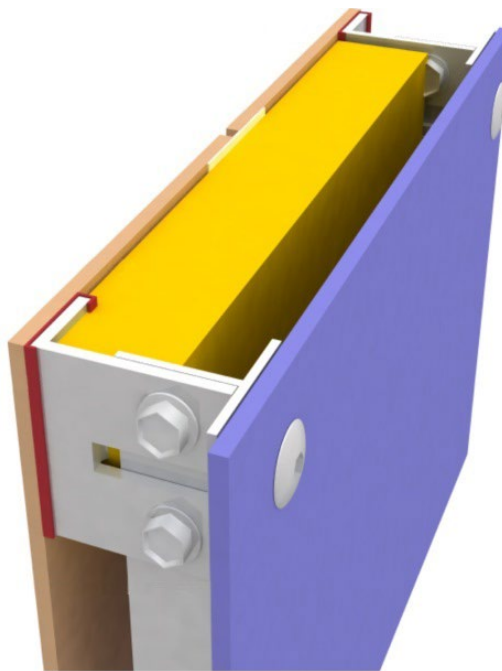

THIRD-PARTY ACCEPTANCE

See section 3.3 (Third-Party Acceptance).

STATEMENT

It is the opinion of Kiwa Ltd., that the System is fit for its intended use, provided it is specified, installed and used in accordance with this Agrément.

Craig Devine
 Operations Manager, Building Products

Alpeo Mlotha CEng FIMMM MBA
 Business Unit Manager, Building Products

SUMMARY OF AGREEMENT

This document provides independent information to specifiers, building control personnel, contractors, installers and other construction industry professionals considering the fitness for the intended use of the System. This Agreement covers the following:

- Conditions of use;
- Production Control, Quality Management System and the Annual Verification Procedure;
- System components and ancillary items, points of attention for the Specifier and examples of details;
- Installation;
- Independently assessed System characteristics and other information;
- Compliance with national Building Regulations, other regulatory requirements and Third-Party Acceptance, as appropriate;
- Sources.

MAJOR POINTS OF ASSESSMENT

Moisture control - the System (see section 2.2.9):

- can contribute to limiting the risk of interstitial and surface condensation;
- can withstand and resist wind-driven rain.

Strength - the System has adequate strength to resist wind loads normally encountered in the UK (see section 2.2.10).

Fire performance - the System (see section 2.2.11):

- can achieve European Classification A2-s1, d0, in accordance with BS EN 13501-1 in certain System variants;
- can contribute to a fire resistance classification EI 120, in accordance with BS EN 13501-2.

Thermal performance - the System improves the thermal performance of external walls and can contribute to satisfying the requirements of the national Building Regulations (see section 2.2.12).

Durability - the System will have a service life equivalent to that of the building into which it is incorporated (see section 2.2.13).

UKCA and CE marking - the System component manufacturers have responsibility for conformity marking in accordance with all relevant British and European Product Standards (see section 2.2.14)

CONTENTS

Chapter 1 - General considerations

- 1.1 - Conditions of use
- 1.2 - Production Control and Quality Management System
- 1.3 - Annual Verification Procedure - continuous surveillance

Chapter 2 - Technical assessment

- 2.1 - System components and ancillary items
- 2.2 - Points of attention to the Specifier
- 2.3 - Examples of details
- 2.4 - Installation
- 2.5 - Independently assessed System characteristics

Chapter 3 - CDM, national Building Regulations and Third-Party Acceptance

- 3.1 - The Construction (Design and Management) Regulations 2015 and The Construction (Design and Management) Regulations (Northern Ireland) 2016
- 3.2 - The national Building Regulations
- 3.3 - Third-Party Acceptance

Chapter 4 - Sources

Chapter 5 - Amendment history

Chapter 6 - Conditions of use

CHAPTER 1 - GENERAL CONSIDERATIONS

1.1 - CONDITIONS OF USE

1.1.1 Design considerations

See section 2.2.

1.1.2 Application

The assessment of the System relates to its use in accordance with this Agrément and the Agrément holder's requirements.

1.1.3 Assessment

Kiwa Ltd. has assessed the System in combination with relevant test reports, technical literature, the Agrément holder's quality plan, DoPs and site visit as appropriate.

1.1.4 Installation supervision

The quality of installation and workmanship shall be controlled by a competent person who shall be an employee of an Approved Installer.

The System shall be installed strictly in accordance with the instructions of the Agrément holder and the requirements of this Agrément.

1.1.5 Geographical scope

The validity of this document is limited to England, Wales, Scotland, Northern Ireland and Ireland, with due regard to Chapter 3 of this Agrément (CDM, national Building Regulations and Third-Party Acceptance).

1.1.6 Validity

The purpose of this BDA Agrément® is to provide for well-founded confidence to apply the System within the Scope described. The validity of this Agrément is three years after the issue date, and as published on www.kiwa.co.uk/bda.

1.2 - PRODUCTION CONTROL AND QUALITY MANAGEMENT SYSTEM

Kiwa Ltd. has determined that the Agrément holder fulfils all obligations in relation to this Agrément, in respect of the System.

The initial audit demonstrated that the Agrément holder has a satisfactory Quality Management System (QMS) and is committed to continuously improving their quality plan. Document control and record-keeping procedures were deemed satisfactory. A detailed Production Quality Specification (PQS) has been compiled to ensure traceability and compliance under the terms of this Agrément.

1.3 - ANNUAL VERIFICATION PROCEDURE - CONTINUOUS SURVEILLANCE

To demonstrate that the System conforms with the requirements of the technical specification described in this Agrément, an Annual Verification Procedure has been agreed with the Agrément holder in respect of continuous surveillance and assessment, and auditing of the Agrément holder's QMS.

This Agrément does not constitute a design guide for the System. It is intended as an assessment of fitness for purpose only.

2.1 - SYSTEM COMPONENTS AND ANCILLARY ITEMS

2.1.1 System components included within the scope of this Agrément

The following components are integral to the use of the System:

Item	Description	Proprietary brand	Specification
sheathing board	calcium silicate fibre cement particle board	RCM Y-wall	9, 12 and 15 mm thick
	fibre cement particle board	RCM Superflex	9 and 12 mm thick
	cement bonded particle board (hereinafter 'CBPB')	RCM Cemboard	10 and 12 mm thick
tape	single-sided tape to seal joints of sheathing boards	illbruck ME315	-
breather membrane	polyester-based breather membrane	illbruck ME010	S_d -value = 0.04 m, watertight (W1)
	polypropylene-based breather membrane	Proctor Wraptite	S_d -value = 0.039 m, watertight (W1)
	reflective breather membrane, manufactured in accordance with BS EN 13859-2	Thermic Technology PhotonWrap	1.35 m wide by 50 m long roll by 0.15 mm thick
insulation board	rock mineral wool (hereinafter 'RMW')	Knauf Earthwool® Rainscreen slab	fire class: A1, $\lambda_D = 0.034$ W/mK
		Rockwool Rainscreen Duo slab	fire class: A1, $\lambda_D = 0.034$ W/mK
subframe	aluminium brackets and vertical rails (L/T-profiles)	Allface subframe F1.10	-
	isolator pad	Allface isolator pad F1/F1+	5 mm thick, $\lambda = 0.49$ W/mK
		RCM Y-Wall isolator pad	up to 15 mm thick
cladding panel	wall cladding panel	Swisspearl Largo	8 or 12 mm thick, $\leq 1,250$ mm by 3,050 mm
fixings	rivet	Swisspearl rivet K15	4.0 mm by 18 mm and 4.0 mm by 24 mm
	rivet sleeve to support the self-weight of a panel	Swisspearl fixed point sleeve (Type 8)	9.4 mm diameter aluminium ring, to suit 9.5 mm diameter hole
	self-drilling screw to connect wall brackets to the LGSF supporting wall	Ejot screw JT3	JT 3-3 6.3 mm by 50 mm
	subframe fastener: self-drilling screw to connect vertical rails (L/T-profiles) and brackets	Ejot screw JT4	JT4-4 4.8 mm by 19 mm

2.1.2 Ancillary items falling outside the scope of this Agrément

Ancillary items detailed in this section may be used in conjunction with the System but fall outside the scope of this Agrément:

- plasterboard - lining board for the inside of the external wall, including associated ancillary items e.g. drywall screws, drywall tape and joint filler;
- cavity barriers - AIM open state cavity barriers (hereinafter 'OSCB') supplied in four variants, for cavities of 250 to 400 mm with an air gap of 25 mm (white/red) or 44 mm (blue/black): fire seal for 1 hour (white/blue) or 2 hours (red/black);
- vapour control layer (hereinafter 'VCL') - to be applied at the warm side of the insulation, if required;
- membrane and adhesive - illbruck ME 220 EPDM membrane for an airtight seal of the wall-window interface, to be fixed with OT015 high-tack membrane adhesive;
- damp-proof membrane (hereinafter 'DPM')/cavity trays - moisture protection for cavity barriers and window frames;
- angle profiles - Swisspearl angle profiles for vertical support of cladding panels in inner or outer corners, 60 mm by 60 mm or 60 mm by 70 mm;
- perforated angle profile - ventilation screen to prevent birds and rodents from entering the air gap behind the cladding panels;
- U or F-profile - profile to joint the edge of a cladding jamb board to the window frame;
- fixings:
 - TIMco wing-tip screw 4.8 mm by 38 mm - fastener to fix sheathing to the LGSF supporting wall, self-drilling screw;
 - bracket fixings - to fix brackets, with or without isolators, to the LGSF supporting wall;
 - insulation fixings - screw with disc/washer to fix the insulation to the supporting wall sheathing.
- sealant:
 - Swisspearl LUKO sealer to finish cut edges of cladding panels;
 - fire stopping - intumescent sealant to seal joints around penetrations or the gaps in openings.

2.2 - POINTS OF ATTENTION TO THE SPECIFIER

2.2.1 Design responsibility

Project-specific design is the responsibility of a Specifier, who shall co-operate with the Agrément holder.

2.2.2 Applied building physics (heat, air, moisture)

A competent specialist shall check the physical behaviour of a project-specific design incorporating the System, and if necessary can offer advice in respect of improvements to achieve the final specification. The Specialist can be either a qualified employee of the Agrément holder or a suitably qualified consultant (in which case it is recommended that the consultant Specialist co-operates closely with the Agrément holder).

2.2.3 General design considerations

A competent specialist can advise in respect of improvements to achieve the final specifications. It is recommended that the Specialist co-operates closely with the Agrément holder.

Due consideration shall be given to the minimum width of 10 mm of the (open) joints between the cladding panels and of the 50 mm air gap directly behind the cladding panels.

Ventilation screens shall be provided to prevent the ingress of birds and animals into the air gap behind the cladding panels.

The design of joints at openings, particularly around windows and doors, shall be in accordance with BS 6093.

A condensation risk analysis (hereinafter 'CRA') shall be completed in accordance with BS 5250.

The LGSF supporting walls shall be designed in accordance with BS EN 1993-1-3 / I.S. EN 1993-1-3. The following variations are possible:

- infill wall (studs between the floor edges);
- continuous wall (studs run past the floor edges).

Wind loads shall be calculated in accordance with BS EN 1991-1-4 / I.S. EN 1991-1-4. Specify the span of the vertical rails (L/T-profiles), spacing of the brackets and appropriate fixings accordingly.

The strength of connections to the supporting wall as reported in this Agrément only apply to the connections as tested. In practice, the strength of these connections can vary between each project-specific design and may vary from the reported values. Assessment of the structural performance of the System shall be carried out by a qualified structural engineer to confirm that the System can resist the design wind loads, can safely transfer loads to the building and can accommodate all anticipated thermal movements without damage.

Fixings for brackets that differ from those detailed in this Agrément may only be specified if test reports from an accredited laboratory confirm the pull and shear strength of the fixings is adequate for the design wind loads and self-weight of the System.

Follow Allface guidance in respect of the subframe design.

Use cavity barriers to control the spread of smoke and fire. Cavity barriers may also be used for pressure equalisation, to improve System resistance to rain penetration.

CBPB sheathing boards are not permitted for use in a relevant building in England (as defined in the national Building Regulations).

2.2.4 Project-specific design considerations

No pre-installation survey is required for the installation of the System.

The 'peak velocity pressure' ($q_p(z)$) and the external pressure coefficients ($c_{pe,1}$ and $c_{pe,10}$) for each zone of a vertical wall shall be determined by the Structural Engineer using the following coefficients:

- $c_{pe,1}$ to determine the wind load on fasteners for the cladding (rivets) and the subframe (screws); and
- $c_{pe,10}$ to determine the wind load on brackets.

The Structural Engineer shall provide a report on building movements and allowed deviations or tolerances. This report shall give an estimate for the:

- horizontal and vertical deflections of beams/floor edges during construction and in-service life;
- permitted deviations or tolerances relating to plumb and (floor) edge position.

Subframe brackets shall be specified with a length/depth that is 45 mm larger than the required thickness of the insulation boards.

Penetrations (e.g. power cables, conduits, vents and flues) shall be clearly marked on a drawing showing the exact position, aperture dimensions, and if required 'fixture element' for fixing a protection pipe. It is the responsibility of:

- the installer of the System to seal the perimeter/edges of the 'fixture element';
- other trades to carry out the installation and sealing of protection pipes and any cables/conduits running through protection pipes.

2.2.5 Permitted applications

Only applications designed according to the specifications given in this Agrément are permitted. In each case the Specifier will have to co-operate closely with the Agrément holder.

2.2.6 Installer competence level

The System shall be installed strictly in accordance with the instructions of the Agrément holder and the requirements of this Agrément.

Installation shall be by an Approved Installer trained and approved by the Agrément holder.

2.2.7 Delivery, storage and site handling

The System components are delivered to site in suitable packaging bearing relevant identification information (for example, production identification code or batch number).

Prior to installation, store the System components in accordance with the Agrément holder's requirements. When required, particular care shall be taken to:

- avoid exposure to direct sunlight for extended periods of time;
- avoid exposure to high or low temperatures for extended periods of time;
- store in a well-ventilated covered area to protect from rain, frost and humidity;
- store away from possible ignition sources.

Detailed information regarding storage can be found in the System component manufacturer's guidelines.

2.2.8 Maintenance and repair

Once installed, the System does not require regular maintenance. For advice in respect of repair, consult the Agrément holder.

In normal conditions, cleaning will not be required as rain will periodically wash away dust, environmental dirt, etc. Remove algae/fungi with a 5 % solution of hydrogen peroxide (H₂O₂) to eliminate all spores.

Performance factors in relation to the Major Points of Assessment

2.2.9 Moisture control

Condensation risk

A CRA shall be completed at the design stage. Based upon the result of the CRA, application of a VCL on the warm side of the insulation shall be considered.

External walls incorporating the System will adequately limit the risk of interstitial and surface condensation, when designed and constructed in accordance with BS 5250.

Resistance to precipitation including wind-driven rain

The System is suitable for use in all wind-driven rain exposure zones, in accordance with BS 8104. In areas of very severe exposure, a breather membrane shall be applied to cover the insulation boards.

To contribute to the airtightness of the wall and reduce the risk of rain penetration:

- construct compartments to create pressure equalisation to limit rain penetration through the 10 mm wide (open) joints between wall cladding panels;
- include a 50 mm wide air gap directly behind the wall cladding panels;
- tape or seal the butt joints of sheathing boards and at interfaces with other building elements;
- the (open) joints between the wall cladding panels shall be 10 mm wide.

Where openings are larger than 10 mm, provide a ventilation screen to prevent birds and animals entering the cavity, e.g. at penetrations and at the top or bottom of the System.

2.2.10 Strength

Wind actions shall be calculated in accordance with BS EN 1991-1-4 / I.S. EN 1991-1-4. Due consideration shall be given to the higher-pressure coefficients applicable to the corners of a building.

The 8 mm thick cladding panels are vulnerable to soft-body impact loads (50 kg) and shall not be used in locations vulnerable to damage (e.g. public areas).

Testing the connection to the LGSF supporting wall shall take into account the intermediate material (sheathing, isolators, etc.) between the steel stud and the bracket. Testing shall be conducted according to a test method and principles as described in EAD 090062-00-0404:

- test at least five specimens, each with one asymmetrical bracket. Do not test with two asymmetrical brackets fixed to the profile of the upper mobile part of the test apparatus;
- subject brackets to a succession of cycles (in each cycle, an increasing load is applied and then returned to zero); do not test with continuous loading until failure;
- the test method and principles in Annex L of EAD 090062-00-0404 are identical to Annex H of EAD 090034-00-0404.

Guidance on fasteners for wall cladding systems can be found in MCRMA Technical Paper No 12.

2.2.11 Fire performance

The propensity for the continuous smouldering of thermal insulation materials, in accordance with BS EN 16733, has not been tested (refer to clause 2.2.3 of EAD 090062-00-0404).

Relevant buildings

Special fire requirements apply where a building is designated a relevant building in accordance with the national Building Regulations. This includes a requirement that materials used in relevant buildings shall achieve a particular European classification for reaction to fire. Refer to the national Building Regulations for the full definition of a relevant building and the restrictions that apply.

Due to the reaction to fire classification, the following product is prohibited for use in the System when the System is installed in a relevant building:

- RCM Cemboard (CBPB sheathing boards) (reaction to fire classification B-s1, d0).

Fire resistance

The fire resistance class of some System variants is EI 120 in accordance with BS EN 13501-2. A range of typical System variants are given in Table 1, based on tested assemblies as described in section 2.5.3.

Table 1 - System variants (without cladding panels) that achieve fire class EI 120

System variant	Plasterboard	Steel studs	Sheathing	Insulation
1b (from inside)	2 off 15 mm (Knauf fire panel)	90 mm deep, 1.2 mm thick	12 mm RCM Y-wall or RCM Superflex	-
2 (from inside)	2 off 12.5 mm (Knauf fire panel)			75 mm RMW (\pm 50 kg/m ³) on outside
3 (from outside)	2 off 15 mm (Gyproc Soundbloc)		75 mm RMW (\pm 45 kg/m ³) on outside	
3a (from outside)	2 off 12.5 mm (Wallboard)		9 mm RCM Y-wall or RCM Superflex + breather membrane (fire class B-s1, d0)	75 mm RMW (\pm 45 kg/m ³) on outside

Remark: the fire resistance class for a System variant that is similar to variant 1b but with two layers of 12.5 mm thick plasterboard is EI 90/E 120.

To limit the spread of smoke and fire but allow ventilation in normal conditions, install OSCBs or compression-fitted barriers. The cavity is the space between the sheathing and the back of the wall cladding panels.

Reaction to fire

The reaction to fire classification of some System variants is A2-s1, d0, in accordance with BS EN 13501-1.

The System has not been tested for reaction to fire when incorporating the following product:

- RCM Cemboard (CBPB sheathing boards).

Indicative reaction to fire class System variants incorporating CBPB sheathing boards are given in Table 2.

Table 2 - Indicative reaction to fire classification (RtF-class) of System variants (with Swisspearl cladding panels)

RtF-class of system variant	Insulation fire class (type)	Sheathing fire class (brand)	Breather membrane fire class (name)	Remarks
A2-s1, d0	A1 (MW)	A1 (Y-wall/Superflex)	-	RMW shall be $\pm 50 \text{ kg/m}^3$ and $\geq 50 \text{ mm}$
A2-s1, d0	A1 (MW)	A1 (Y-wall/Superflex)	B-s3, d0 (illbruck ME010)	RMW shall be $\pm 50 \text{ kg/m}^3$ and $\geq 50 \text{ mm}$
B-s1, d0	A1 (MW)	B-s1, d0 (RCM Cemboard)	B-s1, d0 (Proctor Wraptite)	RMW shall be $\pm 50 \text{ kg/m}^3$ and $\geq 50 \text{ mm}$
B-s1, d0	A1 (MW)	B-s1, d0 (RCM Cemboard)	B-s3, d0 (illbruck ME010)	RMW shall be $\pm 50 \text{ kg/m}^3$ and $\geq 50 \text{ mm}$

Remarks:

- the System variants in Table 2 are untested with the exception of the first System variant;
- in the absence of a fire classification report, the reaction to fire classifications are based on clause 2.2.1 of EAD 090062-00-0404 (discarding the classification of the breather membrane);
- breather membranes are tested and classified in accordance with BS EN 13501-1 (classification without further testing (CWFT) does not apply);
- the 'RtF-class of system variant' as given may not resemble the fire classification after testing of the whole assembly.

2.2.12 Thermal performance

The U-value of a completed wall construction will depend on the type of insulation, insulation thickness and fixing method.

For the purposes of U-value calculations and to determine if the requirements of the national Building Regulations are met, the thermal resistances of a project-specific design shall be calculated according to BR 443, using the declared thermal conductivity (λ_D) of the insulation boards. Consider the correction ΔU_f as described in BS EN ISO 6946 with regard to point thermal transmittances (χ) caused by brackets and mechanical fasteners for insulation boards.

Guidance on linear thermal transmittance (ψ), heat flows and surface temperatures can be found in the documents supporting the national Building Regulations and BR 497.

The ventilated air gap behind the wall cladding panels increases the total thermal resistance of the façade ($R_{\text{tot}} = 1/U$) by raising the surface resistance (R_{se}); use of insulation boards with a low-emissivity surface adds to that effect.

Use isolator pads to minimise thermal bridges caused by System brackets and rails.

To determine the effect of linear thermal bridges on construction joint details without calculations:

- for dwellings, adopt approved design details (as set out in Approved Construction Details) or default ψ -values given in SAP 2012;
- for non-dwellings, use the generic values as given in BRE document IP 1/06 increased by 0.04 W/mK or 50 % (whichever is greater).

2.2.13 Durability

The System shall have a service life durability equivalent to that of the building into which it is incorporated. The expected lifespan of the building itself shall be at least 30-years.

2.2.14 UKCA and CE marking

There is no relevant product standard for the System.

2.3 - EXAMPLES OF TYPICAL DETAILS

Diagram 1 - F1.150 brackets

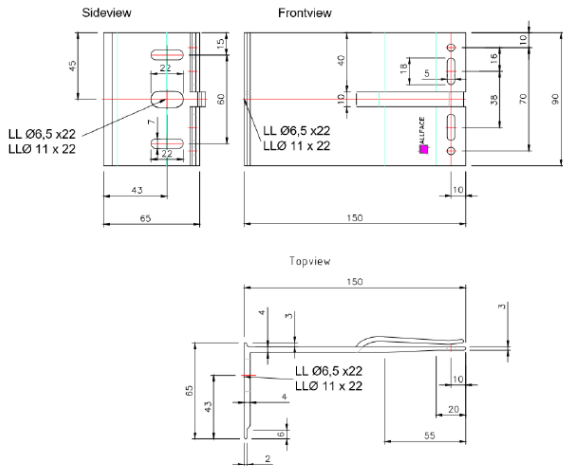

Diagram 2 - Vertical rails (L/T-profiles)

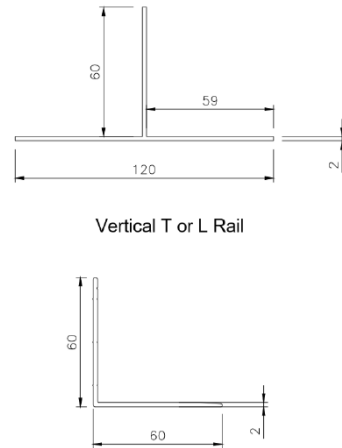

Diagram 3 - Window jamb detail

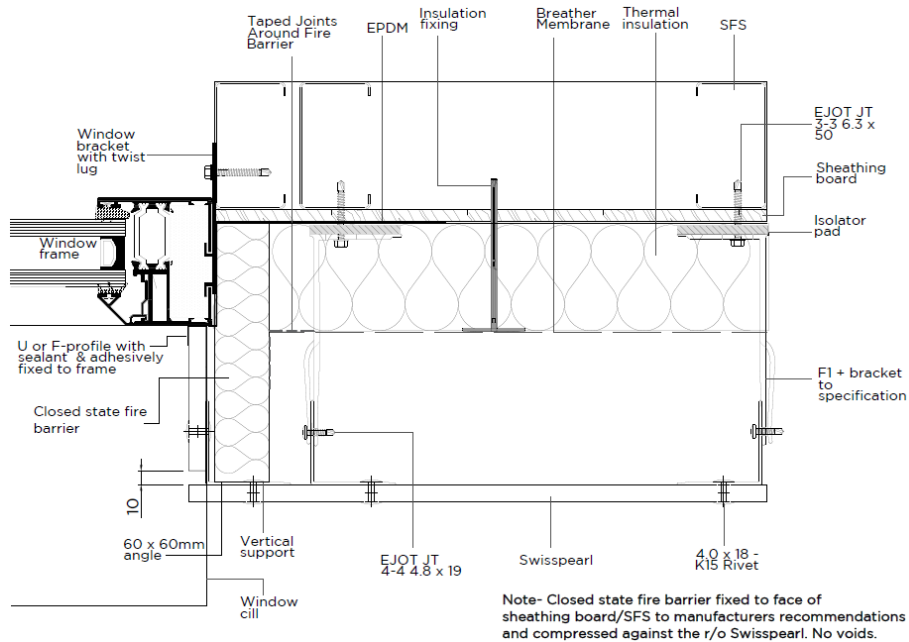

Diagram 4 - Window head detail

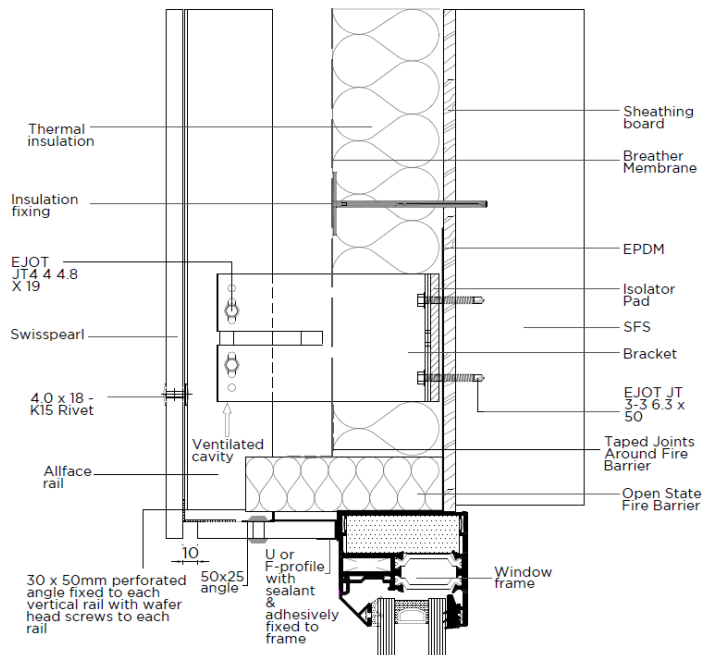

Diagram 5 - External corner detail

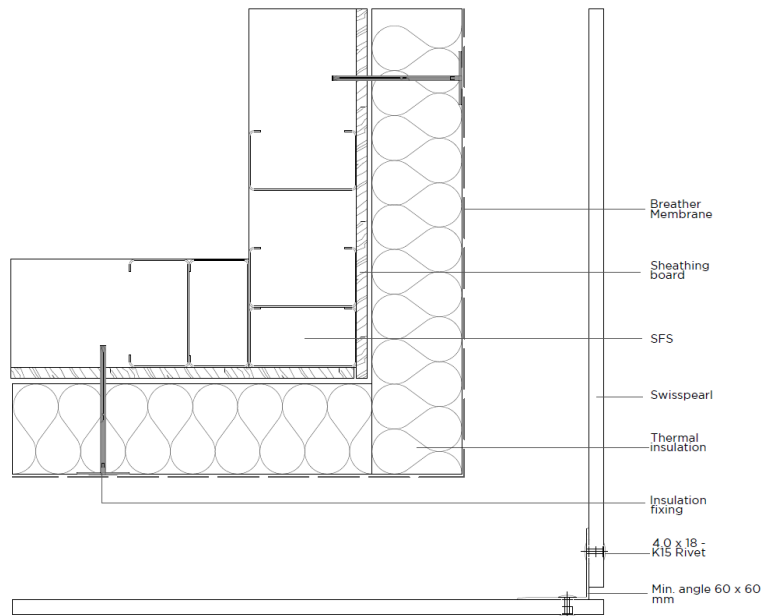

Diagram 6 - Internal corner detail

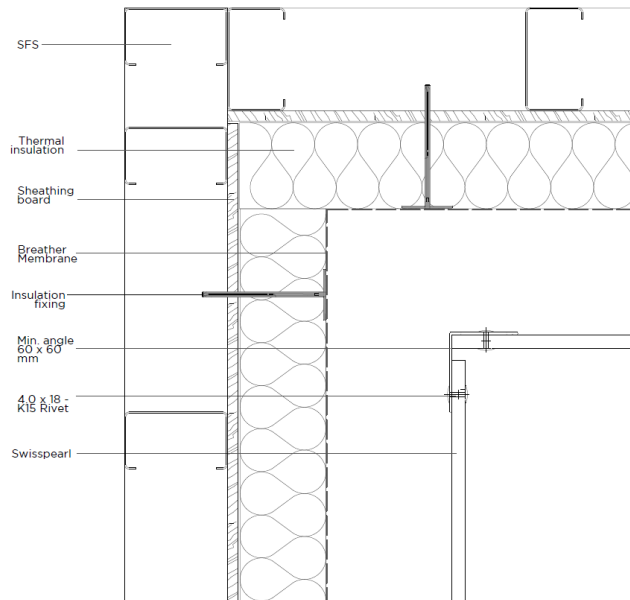

Diagram 7 - Window cill detail

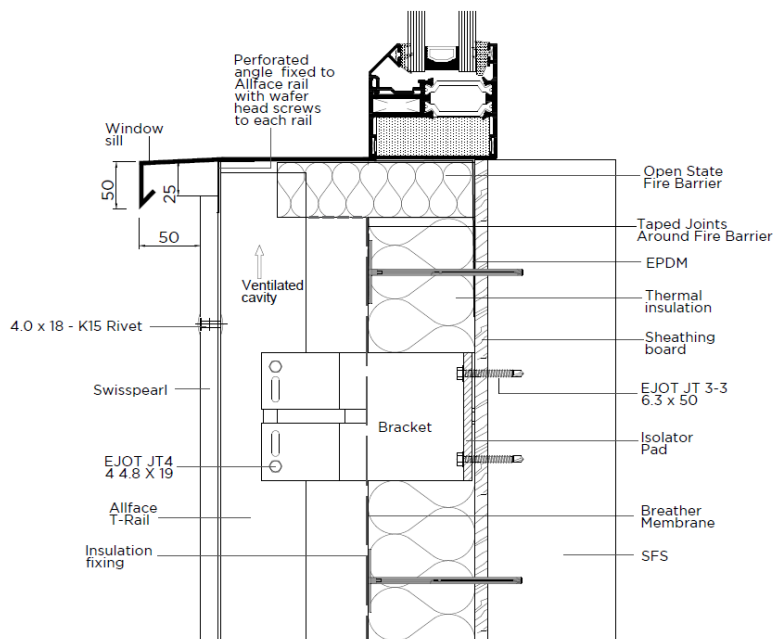
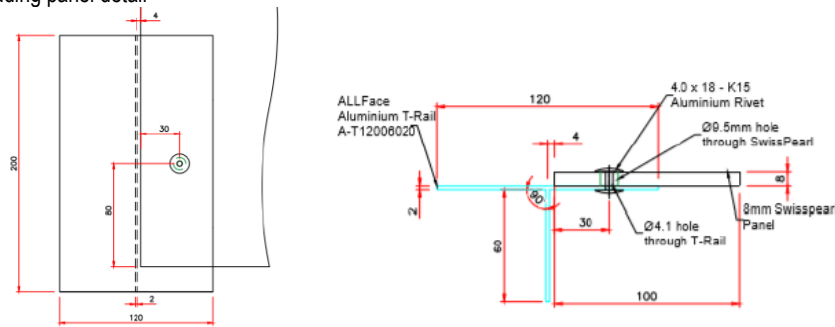

Diagram 8 - Rivet in corner cladding panel detail



2.4 - INSTALLATION

The System shall be installed strictly in accordance with the instructions (hereinafter 'Installation Manual') of the Agrément holder and the requirements of this Agrément.

2.4.1 Installer competence level

See section 2.2.6.

2.4.2 Delivery, storage and site handling

See section 2.2.7.

2.4.3 Project-specific installation considerations

No pre-installation survey is required for the installation of the System.

The Agrément holder provides a service to supply pre-cut, pre-drilled cladding panels to the project-specific design.

2.4.4 Preparation

The following considerations apply before starting the work:

- access to the construction site, parking and unloading of vehicles;
- storage of System components, tools and on-site transport from storage to wall;
- installation of the System (e.g. via scaffolding or using (aerial) lifting equipment).

The following works shall be undertaken before the installation of the System:

- installation of the LGSF supporting wall;
- checking the LGSF supporting wall for correct position, level and plumb in respect of:
 - gaps under the base rail; if present, shims under studs and grouting under the whole length of the base rail may be required;
 - the vertical position of members: within +/-5 mm per storey relative to the base;
 - the horizontal position of base rails: variation in alignment not more than 5 mm in 10 m.

2.4.5 Outline installation procedure

The detailed installation sequence can be found in full in the Agrément holder's Installation Manual.

The key sequence for installation is:

- install the sheathing boards using TIMco wing-tip 4.8 mm by 38 mm fasteners, avoiding four-way joints (stagger the boards);
- create an airtight layer by taping the joints of the sheathing boards using illbruck ME315 tape;
- if service penetrations are required (e.g. cables, vents, flues, etc.), cut holes in the sheathing board for installation of a protection pipe. If required, fix a duct collar/flange or wall spigot plate around the hole and seal using backing rod and elastic weatherproof sealant;
- in zones subjected to very severe exposure Proctor Wraptite or illbruck ME010 breather membrane shall cover the insulation boards. The position of the LGSF supporting wall vertical members shall be marked as work progresses;
- create an airtight and weatherproof wall-window interface by using strips of illbruck ME220 EPDM membrane and OT015 adhesive;
- install the Allface brackets to the LGSF supporting wall in conjunction with Allface or RCM Y-Wall isolator pads to ensure correct alignment on uneven surfaces;
- install the Allface brackets to the LGSF supporting wall using Ejot JT3 6.3 mm by 50 mm fasteners fixing through isolator pads and sheathing board;
- install the insulation boards using fasteners with plastic and stainless steel washers to the pattern provided in the Agrément holder's Installation Manual. To ensure the required air gap is maintained at 50 mm, the length of the Allface brackets shall be 45 mm greater than the insulation board thickness;
- install the Allface subframe vertical rails (L/T-profiles) by sliding between the curved lip and 'leg' of the Allface bracket; insert at least 20 mm and use Ejot JT4 4.8 mm by 19 mm fasteners to connect the rail to the Allface bracket, using slotted holes for sliding connections;
- compartment the cavity to prevent the potential spread of smoke and fire through the cavity and to achieve pressure equalisation to contribute to resisting rain penetration; cavity barriers provided around openings may be formed by the window or door frame (with a minimum thickness of 0.5 mm steel or 38 mm timber) or cavity closers may be used;
- install the cavity barriers with a thickness adequate for the required performance;
- install the Swisspearl cladding panels in a portrait or landscape orientation (panels shall all point in one and the same direction) using vacuum handles with silicone cups. The minimum distances of the centre of a rivet hole to a vertical edge and to a horizontal edge are 30 mm and 60 mm respectively, all rivet holes in a panel shall have a diameter of 9.5 mm, while holes in the vertical rails shall have a diameter of 4.1 mm. Secure every panel by starting with two fixed points using Swisspearl fixed point sleeves;
- edges of Swisspearl cladding panels cut on site shall be sealed using Swisspearl LUKO sealer;
- do not install joint profiles (L-flashing or T-shaped flashing) to seal horizontal open joints of 10 mm between the boards.

Compartment the cavity as follows:

- install a horizontal cavity closer at each floor level;
- install vertical cavity closers at centres not exceeding 6 m;
- install vertical cavity closers at centres not exceeding 1.5 m within 6 m of an internal or external corner;
- install a vertical cavity closer as close as possible to an external corner, generally within 300 mm;
- other methods may be used if supported by suitable assessment.

2.4.6 Finishing

The following finishing is required on completion of the installation:

- clean the System to remove any staining sustained during installation:
 - non-calcium-based stains: remove dust with water at a maximum pressure of 80 bar;
 - calcium-based stains: apply a mist spray of a solution of 10% acetic acid in water;
 - for rust and other metal stains: use hydrochloric acid (5%) or similar detergent.

2.5 - INDEPENDENTLY ASSESSED SYSTEM CHARACTERISTICS

Values reported in this section are taken from the results of testing and assessment of specific System configurations. Other System configurations are possible and shall be approved by the Agrément holder.

2.5.1 Moisture control

Element		Property	Result	Comment
Breather membrane	illbruck ME010	WVT	$S_d = 0.04$ m 0.20 MN·s/g	Diffusion-equivalent air layer thickness (wet cup), BS EN ISO 12572 Resistance (MN·s/g) is a calculated value (wet cup)
		Water penetration	W1 / W1	Initial/after ageing, BS EN 1928
	Proctor Wraptite	WVT	$S_d = 0.039$ m 0.195 MN·s/g	Diffusion-equivalent air layer thickness (wet cup), BS EN ISO 12572 Resistance (MN·s/g) is a calculated value (wet cup)
		Water penetration	W1 / W1	Initial/after ageing, BS EN 1928
	Thermic Technology PhotonWrap	WVT	$S_d = 0.019$ m	Diffusion-equivalent air layer thickness (wet cup), BS EN ISO 12572
		Water penetration	W2	BS EN 1928
Sheathing board	RCM Y-wall	WVT	$S_d = 0.341$ m $\mu = 57^{\wedge}$	Mean value (dry cup) for 6 mm
	RCM Superflex		$S_d = 0.291$ m $\mu = 46^{\wedge}$	Mean value (dry cup) for 6.4 mm
	RCM Cemboard		$S_d = 1.370$ m $\mu = 131^{\wedge}$	Mean value (dry cup) for 10.5 mm
Insulation	Knauf Earthwool®	WVT	$\mu = 1$	Tabulated value
		Water absorption, W_p	< 1 kg/m ²	Short term (24 hours)
	Rockwool Rainscreen Duo Slab	WVT	$\mu = 1$	Tabulated value
		Water absorption, W_p	1.41 kg/m ²	Short term (24 hours), mean value, BS EN ISO 29767

[^] calculated from S_d and thickness

2.5.2 Strength

Test/Element		Characteristic	Values(s) [^]
Rivet - pull from panel	Assembly: <ul style="list-style-type: none"> • Swisspearl Largo cladding panel (8 mm thick); • aluminium profile (2 mm thick); • Swisspearl 4.0 x 18 - K15 rivets (mandrel = EN 1.4541/AISI 321, body = AIMg3). 	Centre of panel	$F_k = 2,053$ N $F_d = 811$ N
		30 mm from edge of panel	$F_k = 1,249$ N $F_d = 494$ N
		30/80 mm from corner of panel	$F_k = 980$ N $F_d = 387$ N
			$F_k = 1,469$ N $F_d = 581$ N
Rivet - shear strength	Swisspearl 4.0 x 18 - K15 rivets	Shear strength	$F_m = 2,332$ N $F_k = 2,040$ N $F_d = 1,535$ N
Rivet - pull strength	Assembly: <ul style="list-style-type: none"> • 2 mm thick aluminium profile; • Swisspearl 4.0 x 18 - K15 rivets 	Pull-out strength	$F_m = 2,332$ N $F_k = 2,040$ N $F_d = 1,535$ N
Soft/hard body impact	Swisspearl Largo cladding panel (8 mm thick)	Soft body (50 kg bag), pass ^{^^}	100 J
		Hard body (1 kg steel ball), pass	10 J
Bracket to LGSF supporting wall	Assembly: <ul style="list-style-type: none"> • LGSF supporting wall: 1.2 mm thick METSEC 090M12-50 (grade S450), • Bracket: Allface F1.320 with fixing; • Fixing: Ejot JT3-3-6.3 x 50 (self-drilling screw). 	F1.320 - Shear, vertical load	$F_k = 925$ N $F_d = 505$ N
		F1.320 - Pull, horizontal load	$F_k = 3,795$ N $F_d = 2,090$ N
		F1+.320 - Shear	$F_d = 1,010$ N
		F1+.320 - Pull	$F_d = 2,090$ N
Subframe fastener	Ejot JT4-4-4.8 x 19	Shear strength	$F_k = 5,160$ N $F_d = 2,715$ N

[^] the notations F_m , F_k and F_d refer to mean, characteristic and design values respectively

^{^^} failure occurred at a drop height of 245 mm (impact energy of 120 J), distance between brackets = 630 mm

2.5.3 Fire performance

Test / element	Characteristic	Result (class)	Comment
External fire spread	Reaction to fire (BS EN 13501-1)	A2-s1, d0	Assembly with open joints of 8 mm, an aluminium subframe, a ventilated air gap \geq 30 mm, insulation \geq 50 mm (with fire class A1/A2-s1, d0) and panels with a finish in any colour with $Q_{PCSS} \leq 3.528$ MJ/m ² . Tested with 8 mm thick panels Swisspearl Largo, colour Carat Azurite
Internal fire spread	Resistance to fire (BS EN 13501-2)	EI 90 E 120	System variant 1a: non-loadbearing wall (BS EN 1364-1), assembly: 12 mm RCM Y-wall, 1.2 mm metal studs 90 mm deep and two layers of 12.5 mm Knauf fire panel plasterboard (fire exposed)
		EI 120 E 120	System variant 1b: non-loadbearing wall (BS EN 1364-1), assembly: 12 mm RCM Y-wall, 1.2 mm metal studs 90 mm deep and two layers of 15 mm Knauf fire panel plasterboard (fire exposed)
		EI 120 E 120	System variant 2: non-loadbearing wall (BS EN 1364-1), assembly: identical to 1a, with the exception of the addition of 75 mm RMW (\pm 50 kg/m ³) on the outside
Internal fire spread	Resistance to fire (BS EN 13501-2)	REI 120 RE 120	System variant 3: loadbearing wall with 10 kN per stud (BS EN 1365-1), assembly: 75 mm RMW insulation of 45 kg/m ³ (fire exposed), 12 mm RCM Y-wall, 1.2 mm metal studs 90 mm deep and two layers of 15 mm SoundBloc plasterboard
		EI 120 E 120	System variant 3a: non-loadbearing wall (BS EN 1364-1:2012), assembly: 75 mm RMW insulation of 45 kg/m ³ (fire exposed), Proctor Wraptite breather membrane, 9 mm RCM Y-wall, 1.2 mm metal studs 90 mm deep and two layers of 12.5 mm SoundBloc plasterboard
Sheathing (RCM Y-wall)	Reaction to fire (BS EN 13501-1)	A1	-
Sheathing (RCM Superflex)	Reaction to fire (BS EN 13501-1)	A1	-
Sheathing (RCM Cemboard)	Reaction to fire (BS EN 13501-1)	B-s1, d0	-
Breather membrane (Proctor Wraptite)	Reaction to fire (BS EN 13501-1)	B-s1, d0	Class valid for substrate with a density \geq 870 kg/m ³ and class A2-s1, d0
Breather membrane (illbruck ME010)	Reaction to fire (BS EN 13501-1)	B-s3, d0	Class valid for substrate with a density \geq 25 kg/m ³ and class A1 or A2-s1, d0
Breather membrane (Thermic Tech. PhotonWrap)	Reaction to fire (BS EN 13501-1)	A1	-
Insulation (RMW)	Reaction to fire (BS EN 13501-1)	A1	-

2.5.4 Thermal performance

Element	Thermal conductivity (λ_D) in W/mK	Comment
Knauf Earthwool® Rainscreen Slab, 50 mm to 210 mm thick	0.034	BS EN 12667
Rockwool Rainscreen Duo Slab < 90 mm thick	0.034	
Rockwool Rainscreen Duo Slab \geq 90 mm thick	0.035	
Isolator pads - 5 mm thick	0.40 - 0.49	-
RCM Y-wall	0.195	BS EN 12667
RCM Superflex	0.381	ISO 8302
RCM Cemboard	0.240	

2.5.5 Durability/various properties

	RCM			Swisspearl Largo cladding panels		Knauf Earthwool® Rainscreen Slab	Rockwool Rainscreen Duo Slab
	Y-wall	Superflex	Cemboard	8 mm	12 mm		
Category (BS EN 12467)	A	A	-	A	A	-	-
Class (BS EN 12467)	-	-	-	4	4	-	-
Density (kg/m ³)	1,258 [^]	1,351 [^]	1,400 [^]	-	-	33 - 45	60
Surface Density (kg/m ²)				17.8 ^{^^}	25.9 ^{^^}		

[^] mean value

^{^^} calculated value, taking into account small variations of nominal thickness and water absorption

CHAPTER 3 - CDM, NATIONAL BUILDING REGULATIONS AND THIRD-PARTY ACCEPTANCE

3.1 - THE CONSTRUCTION (DESIGN AND MANAGEMENT) REGULATIONS 2015 AND THE CONSTRUCTION (DESIGN AND MANAGEMENT) REGULATIONS (NORTHERN IRELAND) 2016

Information in this Agrément may assist the client, Principal Designer/CDM co-ordinator, designer and contractors to address their obligations under these Regulations.

3.2 - THE NATIONAL BUILDING REGULATIONS

In the opinion of Kiwa Ltd., the System, if installed and used in accordance with Chapter 2 of this Agrément, can satisfy or contribute to satisfying the relevant requirements of the following national Building Regulations.

3.2.1 - ENGLAND THE BUILDING REGULATIONS 2010 AND SUBSEQUENT AMENDMENTS

- A1 Loading - the System can sustain and transmit combined self-weight and wind loads to the ground via a supporting wall
- B3(1) Internal fire spread (structure) - the System can contribute to the fire performance by an appropriate selection of elements
- B3(4) Internal fire spread (structure) - use cavity barriers to inhibit the spread of fire and smoke via the System air gap
- B4(1) External fire spread - the System can adequately resist the spread of fire over walls. The fire classification of the System is dependent upon the elements selected
- C2(b) Resistance to precipitation - the System prevents precipitation from penetrating an exterior wall
- C2(c) Resistance to condensation - the System can contribute to satisfying this Requirement
- L1(a)(i) Conservation of fuel and power - the System can contribute to limiting heat gains and losses through a wall
- Regulation 7(1) Materials and workmanship - the System is manufactured from suitably safe, durable materials for their application, and can be installed to give a satisfactory performance
- Regulation 26 CO₂ emission rates for new buildings - the System can contribute to satisfying this Requirement
- Regulation 26A Fabric energy efficiency rates for new dwellings - the System can contribute to satisfying this Requirement
- Regulation 26C Target primary energy rates for new buildings - the System can contribute to satisfying this Requirement

3.2.2 - WALES THE BUILDING REGULATIONS 2010 AND SUBSEQUENT AMENDMENTS

- A1 Loading - the System can sustain and transmit combined self-weight and wind loads to the ground via a supporting wall
- B3(1) Internal fire spread (structure) - the System can contribute to the fire performance by an appropriate selection of elements
- B3(4) Internal fire spread (structure) - use cavity barriers to inhibit the spread of fire and smoke via the System air gap
- B4(1) External fire spread - the can System adequately resist the spread of fire over walls. The fire classification of the System is dependent upon the elements selected
- C2(b) Resistance to precipitation - the System prevents precipitation from penetrating an exterior wall
- C2(c) Resistance to condensation - the System can contribute to satisfying this Requirement
- L1(a)(i) Conservation of fuel and power - the System can contribute to limiting heat gains and losses through a wall
- Regulation 7(1) Materials and workmanship - the System is manufactured from suitably safe, durable materials for their application, and can be installed to give a satisfactory performance
- Regulation 26 CO₂ emission rates for new buildings - the System can contribute to satisfying this Requirement
- Regulation 26A Primary energy rates for new buildings - the System can contribute to satisfying this Requirement
- Regulation 26B Fabric performance values for new dwellings - the System can contribute to satisfying this Requirement
- Regulation 26C Energy efficiency rating - the System can contribute to satisfying this Requirement

3.2.3 - SCOTLAND THE BUILDING (SCOTLAND) REGULATIONS 2004 AND SUBSEQUENT AMENDMENTS

3.2.3.1 Regulation 8(1)(2) Durability, workmanship and fitness of materials

- The System is durable and fit for its intended purpose and can contribute to a construction to satisfy this Regulation

3.2.3.2 Regulation 9 Building Standards - Construction

- 1.1 Structure - the System can sustain and transmit combined self-weight and wind loads to the ground via a supporting wall
- 2.4 Cavities - use cavity barriers to inhibit the spread of fire and smoke via the System air gap
- 2.6 Spread to neighbouring buildings - the System can contribute to fire performance by the appropriate selection of elements
- 2.7 Spread on external walls - the System can adequately resist the spread of fire over walls. The fire classification of the System is dependent upon the elements selected
- 2.8 Spread from neighbouring buildings - the System can contribute to fire performance by the appropriate selection of elements
- 3.10 Precipitation - the System prevents moisture from precipitation penetrating to the inner face of the building
- 3.15 Condensation - the System can contribute to satisfying this Requirement
- 6.1(b) Carbon dioxide emissions - a wall incorporating the System can reduce CO₂ emissions
- 6.2 Building insulation envelope - the System can reduce heat loss
- 7.1(a)(b) Statement of sustainability - the System can contribute to satisfying the relevant Requirements of Regulation 9, Sections 1 to 6, and therefore will contribute to a construction meeting a bronze level of sustainability as defined in this Standard. In addition, the System can contribute to a construction meeting a higher level of sustainability as defined in this Standard

3.2.3.3 Regulation 12 Building Standards - Conversions

- All comments given under Regulation 9 also apply to this Regulation, with reference to Schedule 6 of The Building (Scotland) Regulations 2004 and subsequent amendments, clause 0.12 of the Technical Handbook (Domestic) and clause 0.12 of the Technical Handbook (Non-Domestic)

3.2.4 - NORTHERN IRELAND THE BUILDING REGULATIONS (NORTHERN IRELAND) 2012 AND SUBSEQUENT AMENDMENTS

- 23(1)(a)(i)(ii)(iii)(b)(ii) Fitness of materials and workmanship - the System is manufactured from materials which are suitably safe and acceptable as described in this Agrément
- 28(b) Resistance to the weather - the System prevents the passage of moisture to any part of a building
- 29 Condensation - the System can contribute in preventing a harmful effect on the building due to interstitial condensation
- 30 Stability - the System can sustain and transmit combined dead, imposed and wind loads to the ground via the supporting structure
- 35(1) Internal fire spread - the System can contribute to fire performance by the appropriate selection of elements
- 35(4) Internal fire spread - use cavity barriers to inhibit the spread of fire and smoke via the System air gap
- 36(a) External fire spread - the System can adequately resist the spread of fire over walls. The fire classification of the System is dependent upon the elements selected
- 39(a)(i) Conservation measures - the System can contribute to limiting heat gains and losses through walls
- 40(2) Target carbon dioxide emission rate - the System can contribute in meeting the target carbon dioxide emission rate

3.2.5 - IRELAND BUILDING REGULATIONS 1997 AND SUBSEQUENT AMENDMENTS

In order to demonstrate compliance with Irish Building Regulations, this BDA Agrément® certifies that the System complies with the requirements of a recognised document and indicates it is suitable for its intended purpose and use.

- A1 Loading - the System can sustain and transmit combined self-weight and wind loads to the ground via a supporting wall
- B3(1)/B8(1) Internal fire spread (structure) - the System can contribute to the fire performance by an appropriate selection of elements
- B3(3)/B8(3) Internal fire spread (structure) - walls formed from the System can contribute to inhibiting the unseen spread of fire and smoke within concealed spaces
- B4/B9 External Fire Spread - the System can contribute to satisfying this Requirement
- C4 Resistance to weather and ground moisture - the System prevents moisture from precipitation penetrating to the inner face of the building
- D1 Materials and workmanship - the System, when installed in accordance with this Agrément, can meet the relevant Requirements, is manufactured from suitably safe and durable materials for its application and can be installed to give a satisfactory performance
- L1 Conservation of fuel and energy - the System can enable a building to conserve energy and limit CO₂ emissions

3.3 - THIRD-PARTY ACCEPTANCE

In the opinion of Kiwa Ltd. if installed, used, and maintained in accordance with this Agrément, this System can satisfy the appropriate structural, fire, moisture, thermal and durability requirements of a Structural Warranty provider. Please contact the relevant Structural Warranty provider to ascertain their project specific design requirements and to confirm their acceptance on a case-by-case basis.

CHAPTER 4 - SOURCES

- BS EN ISO 6946:2017 Building components and building elements. Thermal resistance and thermal transmittance. Calculation methods
- BS EN ISO 10140-2:2010 Acoustics. Laboratory measurement of sound insulation of building elements. Measurement of airborne sound insulation
- BS EN ISO 10456:2007 Building materials and products. Hygrothermal properties. Tabulated design values and procedures for determining declared and design thermal values
- BS EN ISO 12572:2016 Hygrothermal performance of building materials and products. Determination of water vapour transmission properties. Cup method
- BS EN ISO 29767:2019 Thermal insulating products for building applications. Determination of short-term water absorption by partial immersion
- BS EN 1928:2000 Flexible sheets for waterproofing. Bitumen, plastic and rubber sheets for roof waterproofing. Determination of watertightness
- BS EN 1991-1-4:2005+A1:2010 Eurocode 1. Actions on structures. General actions
- NA to BS EN 1991-1-4:2005+A1:2010. UK National Annex to Eurocode 1. Actions on structures. General actions
- BS EN 1993-1-3:2006 Eurocode 3. Design of steel structures. General rules
- NA to BS EN 1993-1-3:2006. UK National Annex to Eurocode 3. Design of steel structures. General rules.
- BS EN 12467:2012+A2:2018 Fibre-cement flat sheets. Product specification and test methods
- BS EN 12667:2001 Thermal performance of building materials and products. Determination of thermal resistance by means of guarded hot plate and heat flow meter methods. Products of high and medium thermal resistance
- BS EN 13501-1:2018 Fire classification of construction products and building elements. Classification using data from reaction to fire tests
- BS EN 13501-2:2016 Fire classification of construction products and building elements. Classification using data from fire resistance tests, excluding ventilation services
- BS EN 16733:2016 Reaction to fire tests for building products. Determination of a building product's propensity to undergo continuous smouldering
- BS 5250:2011+A1:2016 Code of practice for control of condensation in buildings
- BS 6093:2006+A1:2013 Design of joints and jointing in building construction. Guide
- BS 8104:1992 Code of practice for assessing exposure of walls to wind-driven rain
- ISO 8302:1991 Thermal insulation. Determination of steady-state thermal resistance and related properties. Guarded hot plate apparatus
- BRE Report BR 443 Conventions for U-value calculations, 2006 edition
- BRE Report BR 497 Conventions for calculating linear thermal transmittance and temperature factors, 2016 edition
- BRE document IP 1/06 Assessing the effects of thermal bridging at junctions and around openings, 2006 edition
- EAD 090034-00-0404, Kit composed by subframe and fixings for fastening cladding and external wall elements, June 2016 version
- EAD 090062-00-0404, Kits for external wall claddings mechanically fixed, July 2018 version
- I.S. EN 1993-1-3:2006 Eurocode 3: Design of steel structures. Part 1-3: General rules. Supplementary rules for cold-formed members and sheeting
- I.S. EN 1993-1-3/NA:2006 Irish National Annex to Eurocode 3: Design of steel structures. Part 1-3: General rules. Supplementary rules for cold-formed members and sheeting
- I.S. EN 1991-1-4:2005 Eurocode 1: Actions on structures. Part 1-4: General actions. Wind actions
- I.S. EN 1991-1-4/NA:2005 Irish National Annex to Eurocode 1: Actions on structures. Part 1-4: General actions. Wind actions
- MCRMA Technical Paper No 12, Fasteners for metal roof and wall cladding: design, detailing and installation guide, issued May 2000
- SAP 2012 The Government's Standard Assessment Procedure for Energy Rating of Dwellings, 2012 edition

Remark: apart from these sources, technical information and confidential reports have been assessed; any relevant documents are in the possession of Kiwa Ltd. and kept in the Technical Assessment File of this Agrément. The Installation Manual for the System may be subject to change; contact the Agrément holder for clarification of revisions.

CHAPTER 5 - AMENDMENT HISTORY

Revision	Amendment description	Amended by	Approved by	Date
-	First Issue	C Devine	C Vurley	August 2020
A	Issue with NHBC acceptance	C Devine	C Vurley	June 2021
B	Updated company details to RCM	C Devine	C Vurley	May 2022
C	Addition of Ireland into geographic scope	A Chapman	C Devine	November 2023
D	Re-issue following successful 3 Year Renewal; updated System name; updated Third-Party Acceptance; minor non-technical amendments	A Chapman	C Devine	September 2024

CHAPTER 6 - CONDITIONS OF USE

This Agrément may only be reproduced and distributed in its entirety.

For full terms and conditions refer to Kiwa Ltd.